

## PRIMO INOX stainless steel version 250 kg

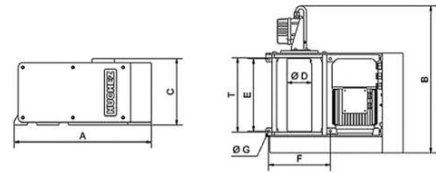

- Range of electric winches designed for simple lifting and pulling applications in a corrosive environment.

### Technical properties

- Very low voltage control ensuring user protection against electric risks.
- Rigid stainless steel aluminium structure (316 L).
- Up--down pendant control with emergency stop, cable 3 m long.
- Single-phase motor brake 230 V or three-phase motor brake 230/400 V - 50 Hz, lifting type, P = 0.75 kW. Isolation class F. IP 66.
- Reducer in oil bath with helical gears.
- Mechanically welded drum with wide flanges allowing a secure fastening of the wire rope.
- Limit switches included (IP 66/67).
- Rope-press roller and grooved drum as optional equipment.

### Technical characteristics of PRIMO INOX stainless steel version 250 kg

References	PRIMO INOX BT 2
Capacity 1st layer kg	300
Capacity top layer kg	250
Nb of layers	4
Wire rope cap. 1st layer m	13
Wire rope Ø mm	5
FEM	1Bm
Motor kW	0,75
Power	1 Ph - 230 V or 3 Ph - 230/400 V
Weight (without cable) kg	40
Speed top layer m/mn	10,3
Speed 1st layer m/mn	7,7
Wire rope cap. on sup. layer m	63

## Dimensions

References	PRIMO INOX BT 2
A mm	476
B mm	528
C mm	244
D mm	85
E mm	250
F mm	214
G mm	9
T mm	257

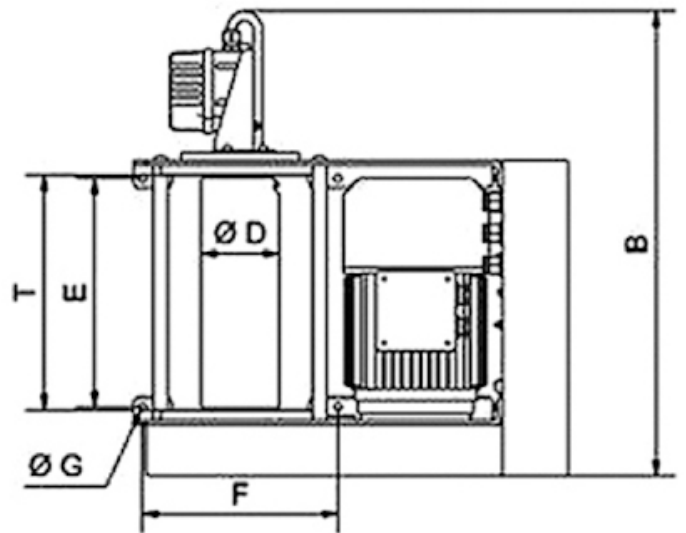
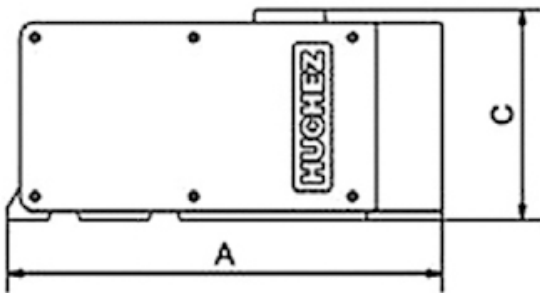

## Technical characteristics of the other models of the range

References	PRIMO INOX BT 251	PRIMO INOX BT 401	PRIMO INOX BT 993
Capacity 1st layer kg	300	400	990
Capacity top layer kg	250	400	990
Nb of layers	4	3	3
Wire rope cap. 1st layer m	13	6	11
Wire rope cap. top layer m			
Wire rope Ø mm	5	6,2	10
FEM	1Bm	1Bm	1Bm
Motor kW	0,75	0,75	1,1
Power	1 Ph - 230 V or 3 Ph - 230/400 V	1 Ph - 230 V or 3 Ph - 230/400 V	3 Ph - 230/400 V
Weight (without cable) kg	40	40	90
Speed top layer m/mn	10,3	8	5,2
Speed 1st layer m/mn	7,7	6,2	4
Wire rope cap. on sup. layer m	63	39	42



HUCHEZ  
 9, Grande Rue  
 60420 FERRIERES – France  
 ☎ +33 (0) 3 44 51 11 33  
 Site internet : [www.huchez.com](http://www.huchez.com)  
 E-mail : [contact@huchez.fr](mailto:contact@huchez.fr)



SERVICE  
 CLIENTS



Pour en savoir plus, n'hésitez pas à nous contacter !  
*To know more, please contact us!*