



FLANGE TOOL INNOVATION

PRODUCT DATA SHEET

NS15TE

EXTERNAL HYDRAULIC NUT SPLITTER

RANGE OF APPLICATION FOR FLANGE NUTS:

HEX NUT A/F: 24.0 mm - 36.6 mm (0.94" - 1.44")
H: Max 22.4 mm (0.88")

TOOL WEIGHT:

4.0 kg (8.8 lb)

KIT CONTENTS

- 1 x NS15TE Nut Splitter
- 1 x Spare Cutting Tip
- 1 x Spare Tip Retention Screw
- 1 x Spare Alignment Screw
- 1 x Set of Hex Keys
- 1 x Safety Lanyard
- 1 x Instruction Manual
- 1 x Carry Case

Product Code: NS15TEMIN



WEIGHTS AND DIMENSIONS

Tool Weight: 4.0 kg (8.8 lb)
Gross Kit Weight: 7.1 kg (16.7 lb)

Carry Case Dimensions:
580 mm x 350 mm x 180 mm
(22.8" x 13.8" x 7.1")

Minimum Pump Oil Capacity:
46 cc (2.8 in³)



info@equalizerinternational.com
www.equalizerinternational.com

NS15TE

EXTERNAL HYDRAULIC NUT SPLITTER



FLANGE TOOL INNOVATION

RANGE OF APPLICATION FOR FLANGE NUTS

NS TOOL	UNC HEAVY HEX STUD SIZE	UNC HEAVY NUT A/F SIZE	METRIC STUD SIZE	METRIC NUT A/F SIZE
NS15	3/4", 7/8"	1.25" to 1.44"	M16, M20, M22	24 mm to 32 mm

PLEASE REFER TO OUR WEBSITE www.equalizerinternational.com FOR INFORMATION ON THE COMPLETE EQUALIZER NUT SPLITTER RANGE

SPATIAL ENVELOPE

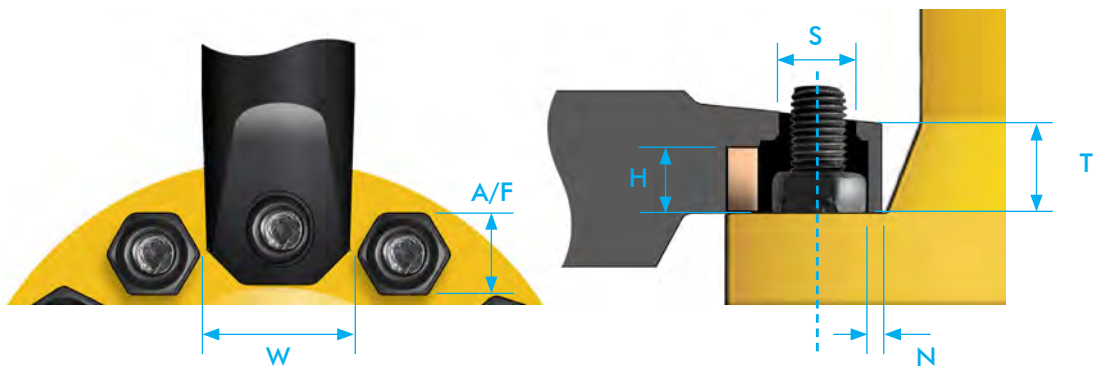

	DIMENSION	MEASURED FROM	MEASURED TO	MINIMUM	MAXIMUM
A/F	Across Flats	Nut Hex Flat	Nut Hex Flat	-	40 mm (1.57")
W	Clear Width	Side Obstruction	Side obstruction	57.5 mm (2.26")	-
S	Protruding Stud Diameter	Stud OD	Stud OD	-	26.5 mm (1.04")
H	Cutting Height	Flange Face	Top of Nut	-	25.0 mm (0.98")
N	Nose Clearance	Nut Flat	Frontal Obstruction	9.0 mm (0.35")	-
T	Nose Height	Flange Face	Top of Nose	32.0 mm (1.26")	