



FLANGE TOOL INNOVATION

# PRODUCT DATA SHEET

## SW9TM MECHANICAL FLANGE SPREADER

### SPREADING FORCE:

With 203 N·m (150 ft·lb) of torque applied: 9.4 T (94 kN)

It is recommended that tools are used in pairs giving:  
2 x 9.4 T = 18.8 T (188 kN)

TOOL WEIGHT: 5.5 kg (12.1 lb)

### KIT CONTENTS

- 1 x SW9TM Wedgehead
- 1 x 203 N·m (150 ft·lb) Torque Wrench with 22 mm socket
- 1 x Safety Block
- 1 x Pair of Stepped Blocks
- 1 x Hex Key
- 1 x Instruction Manual
- 1 x Cardboard Packaging

Product Code: SW90TMMIN



### WEIGHTS AND DIMENSIONS

- Tool Weight: 5.5 kg (12.1 lb)
- Torque Wrench: 1.5 kg (3.3 lb)
- Safety Block: 0.5 kg (1.1 lb)
- Gross Kit Weight: 7.5 kg (16.5 lb)

Packaging Dimensions:  
190 mm x 180 mm x 320 mm  
(7.5" x 7.1" x 12.6")

TOOL DIMENSIONS - CLOSED

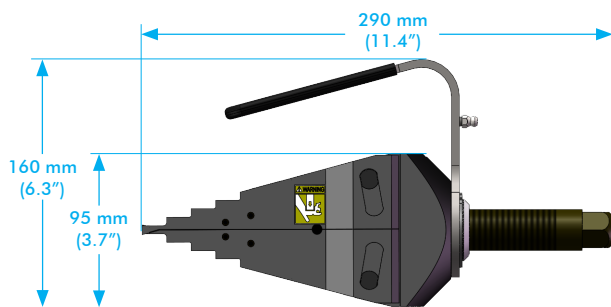

TOOL DIMENSIONS - OPEN

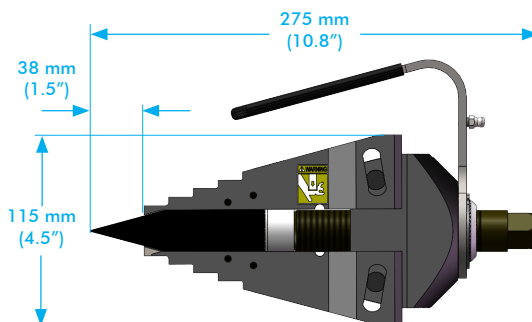

# SW9TM

## MECHANICAL FLANGE SPREADER



FLANGE TOOL INNOVATION

### TOOL DIMENSIONS - CLOSED

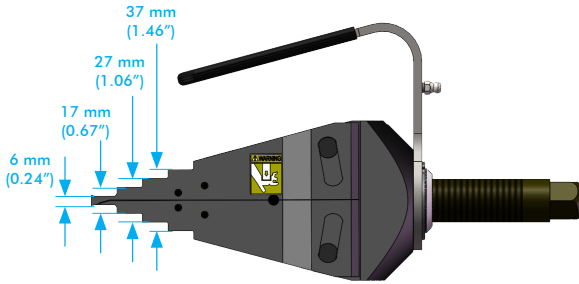

### TOOL DIMENSIONS - OPEN

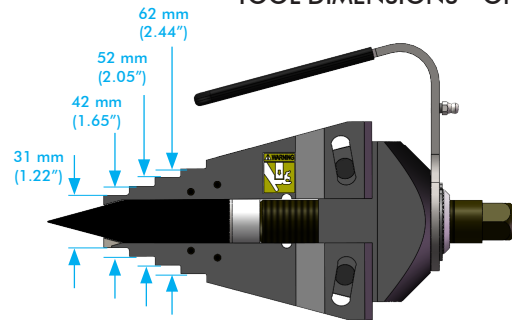

### SAFETY BLOCK DIMENSIONS

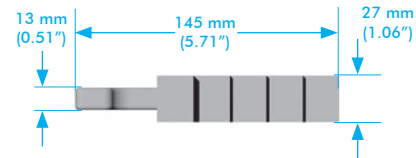
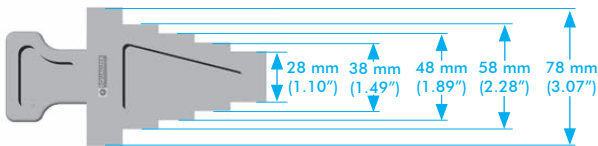

### RANGE OF APPLICATION

All flanges with a minimum access gap of 6 mm (0.24")

ITEM	DESCRIPTION	QTY.
01	WHITE PLASTIC CAP	01 each
02	SERIAL NO STICKER	01 each
03	PINCH POINT STICKER	02 each
04	GREASE POINT STICKER	02 each
05	BADGE LOGO	02 each
06	SWL STICKER	02 each
07	WEDGE	01 each
08*	M5x6 SCKT SCREW	01 set of 4
09*	SLIDE PIN	01 set of 4
10	MAIN BODY (not replaceable)	01 each
11	SPIRAL PIN	01 set of 8
12*	M6x12 GRUB SCREW	01 each
13*	M14 HALF NUT	01 each
14*	BEARING CARRIER	01 each
15	M/F ADAPTOR	01 each
16	HANDLE	01 each
17	EXTERNAL CIRCLIP	01 each
18*	PUSH ROD	01 each
19	M6 GREASE NIPPLE	01 each
20	HANDLE SLEEVE	01 each
21*	THRUST WASHER	02 each
22*	THRUST RACE	01 each
23	JAW (PAIR)	01 pair
24	22mm 1/2" SOCKET	01 each
25	TORQUE WRENCH	01 each

\*Items 8, 9, 12, 13, 21 & 22 are supplied in Repair Kit Part No: 310501-01  
\*Items 14 & 18 are supplied in Repair Kit Part No: 310502-01

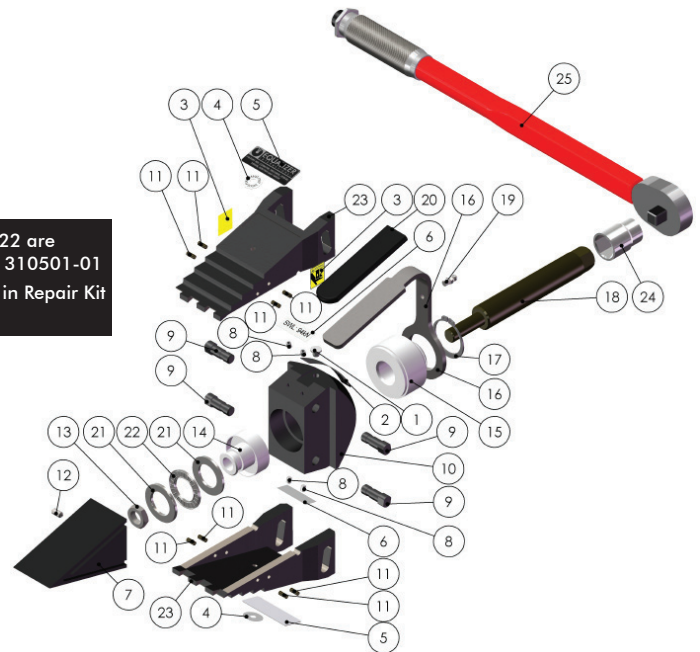

### STEPPED BLOCKS

Stepped Blocks can be used singly or in pairs to increase the maximum spreading distance of the SW9TM to 81 mm

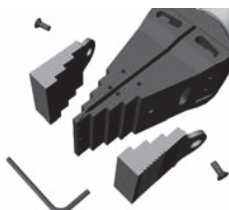

### WEIGHTS AND DIMENSIONS

Stepped Block: 0.52 kg (1.1 lb)  
GROSS WEIGHT: 1.5 kg (3.3 lb)

